



CATALOG 2024



 **GREENWOOD FENCE**™

Where Elegance Meets Durability

Welcome to Greenwood Fence

Step into a world where design meets durability – welcome to Greenwood Fence's 2024 Catalog. As a beacon of innovation since 2019, we're excited to guide you through our curated collection of state-of-the-art composite fencing solutions. Our catalog is more than just a showcase of products; it's an invitation to transform spaces with elegance and strength. Each page unfolds our commitment to sustainability, quality, and the kind of customer experience that turns first-time inquiries into lasting partnerships. Dive in and discover the perfect blend of style, security, and sustainability for your next project.

**DISCOVER MORE AT
GREENWOODFENCE.COM**





Where Elegance Meets Durability

What is a Greenwood Fence?

Greenwood Fence presents a durable composite fencing system combining wood plastic composite boards with stylish aluminum posts and rails. This elegant yet functional solution enhances any outdoor setting. Our Advanced Series boards are sustainably made from recycled materials, offering high density and durability, with a protective shield for longevity and low maintenance. Our commitment lies in innovative design, exceptional customer support, and ensuring our clients receive enduring value and quality that defines our brand.

FOLLOW US



CLASSIC PRIVACY



Wind loading



Warranty



Eco-friendly

CLASSIC SEMI PRIVACY



Low maintenance



Waterproof



Anti-UV

DELUXE SEMI PRIVACY



HORIZONTAL PICKET



DELUXE TRELLIS



Wind loading



Warranty



Eco-friendly

CLASSIC TRELLIS



Low maintenance



Waterproof



Anti-UV

LATTICE SEMI PRIVACY



MODERN PRIVACY



FEATURES



**WHAT SIDE OF THE FENCE
ARE YOU ON?**

No need to pick sides because our double sided composite fence ensures a beautiful boundary from every angle.

**ELEGANT
NEIGHBORLY
DURABLE
BOTH SIDES**

**MENDING
RELATIONSHIPS
ONE FENCE AT A TIME!**

FEATURES



**CREATIVITY
WITH
COMPOSITE
FENCING**



A FENCE FOR EVERY VISION:

EMBRACE THE VERSATILITY OF A CUSTOMIZABLE
GREENWOOD FENCE

PARTS



MODULAR FENCE ELEMENTS

Capped Composite - Easy Install

Our sleek modular fencing system, featuring polymer-capped composite boards, offers rapid and straightforward installation while ensuring robust stability. The system's posts and tongue and groove interlocking covers are crafted from sleek aluminum, providing a durable and elegant finish. This design allows for creative customization, accommodating a range of privacy preferences with its innovative materials.

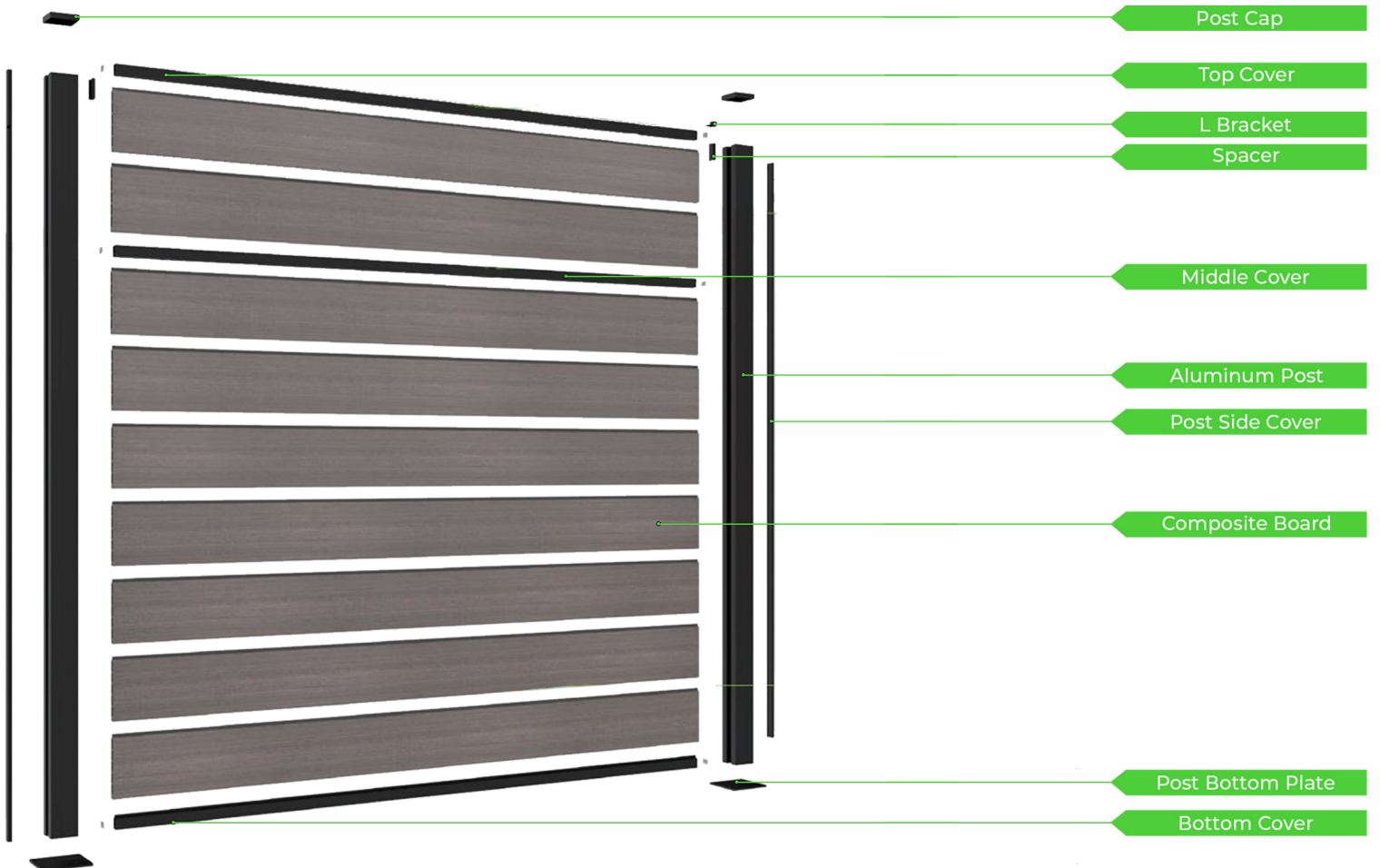

SWIVEL KIT

ADJUSTABLE ANGLE POST

Different Angles, Different Applications

Now with these new aluminum parts, our fence system can be adjusted to very specific angles to accommodate many requirements of different applications.

An axis is inserted into the slot of the post, and the pivot slides over it. The pivot will receive the fence board like a normal line post.

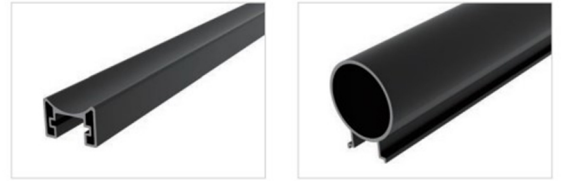

GWF513ASKB

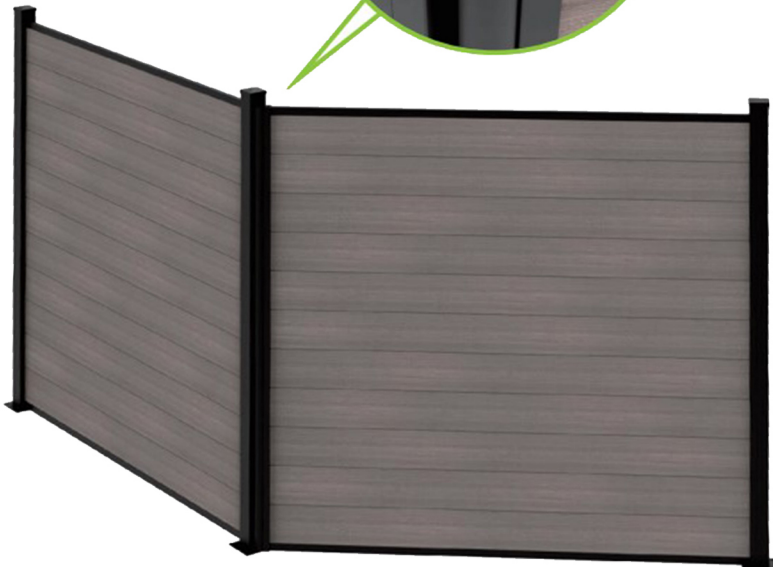
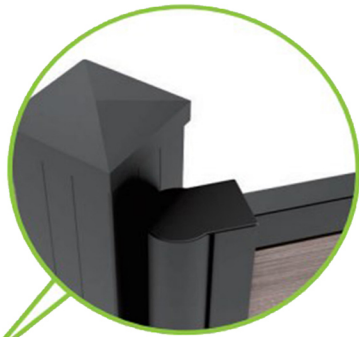
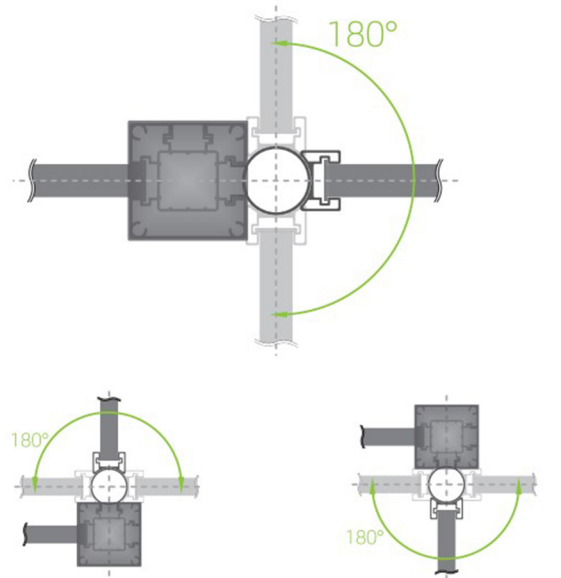

GATES

**Elevate your Space with
Elegance and Strength**

Innovative Aluminum and
Composite Gate Solutions
for the Modern World



Available now at
greenwoodfence.com

GATES

Introducing the GWF Gate Series: Where Elegance Meets Innovation

Crafted for sophistication and designed to last, the GWF Gate Series sets the standard for modern entry solutions. Our gates offer a harmonious blend of durability and low maintenance, ensuring they stand the test of time while maintaining their pristine appearance.

Sleek Design

Each 4-foot-wide gate frame is engineered to accommodate composite or aluminum tongue and groove interlocking boards, ensuring a sleek, coherent look. The seamless frame design conceals hardware and eliminates weld marks, providing a flawless finish that complements any property.

Durability and Quality

Constructed from robust 6063 T6 aluminum alloy, our gates are not just strong but also lightweight. The Qualicoat Certified powder coating process ensures a uniform, durable matte black finish that resists the elements and daily wear. Our commitment to quality means your gate will maintain its integrity and appearance for years to come.

Colorful Customization

Choose from five distinctive colors for board infills to match your style or branding. The full privacy design provides complete seclusion, while the flexible structure allows for semi-privacy customizations to suit your aesthetic and functional preferences.

Optimized Functionality

The 6-foot single and 12-foot double swing gates echo the design principles of the 4-foot model but are exclusively fitted with sleek aluminum boards. This choice not only enhances the visual appeal but also optimizes functionality by maintaining a lighter load, ensuring smooth operation every time.





CONTACT US

WWW.GREENWOODFENCE.COM

INFO@GREENWOODFENCE.COM

1-888-24FENCE